

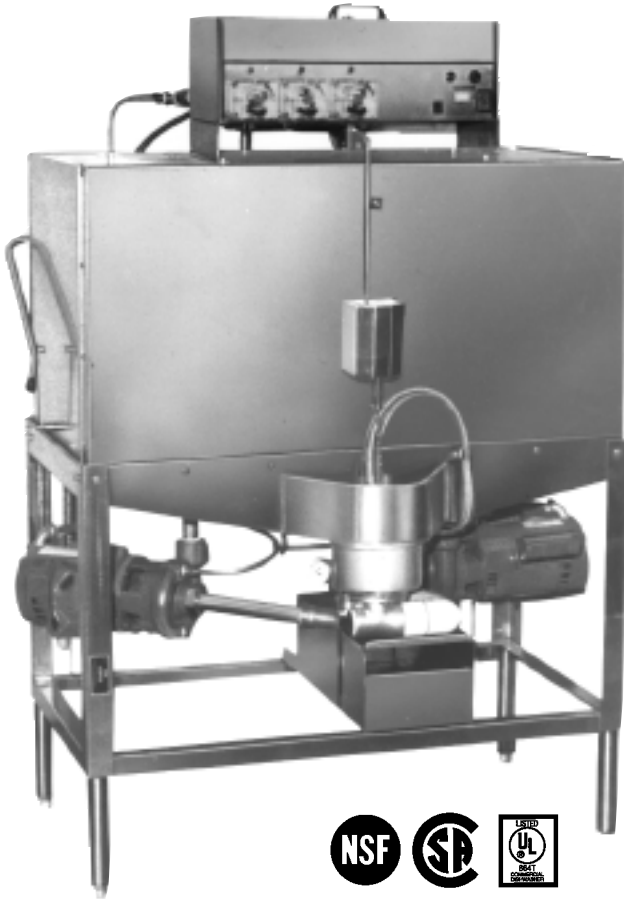

A PROFESSIONAL COMPANY

B
 Chemical Sanitizing
 Double Rack Straight
 Dishwasher

Item. # _____



FEATURES:

- 74 racks / 296 covers per hour.
- Economical to operate. Uses only 3 gallons of water per cycle.
- All heavy duty 304 stainless steel construction assures long life and years of trouble free operation.
- Unique spray arm system features upper and lower stainless steel wash arms with reinforced end caps. Specially designed pull-pins allow wash arms to be easily removed for cleaning.
- Pump purging system improves results by eliminating soil and chemical carryover during rinse cycle.
- Top mounted controls include built-in chemical pumps and delimiting system that assures proper chemical usage.
- Auto start/stop makes operation safe and easy.
- Integrated scrap tray prevents food soil from entering drain system.

Spec. # _____



Optional Temp-Sure™ heater assures a continuous supply of 140°F hot water that guarantees excellent results.



Unique pull-pin design allows wash arms to be easily removed for cleaning.

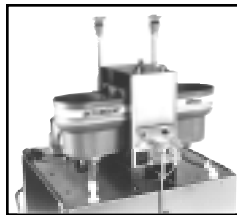

Bowl option available for capsule dispensed products.



Integrated scrap tray prevents food soil from entering drain system.



Top mounted controls include built-in chemical pumps and delimiting system that assures proper chemical usage.

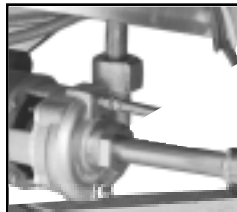

Pump purging system improves results by eliminating soil and chemical carryover during rinse cycle.

AIA # _____



A ~~AMERICAN~~ ~~INDUSTRIAL~~ COMPANY

B
**Chemical Sanitizing
 Double Rack Straight
 Dishwasher**

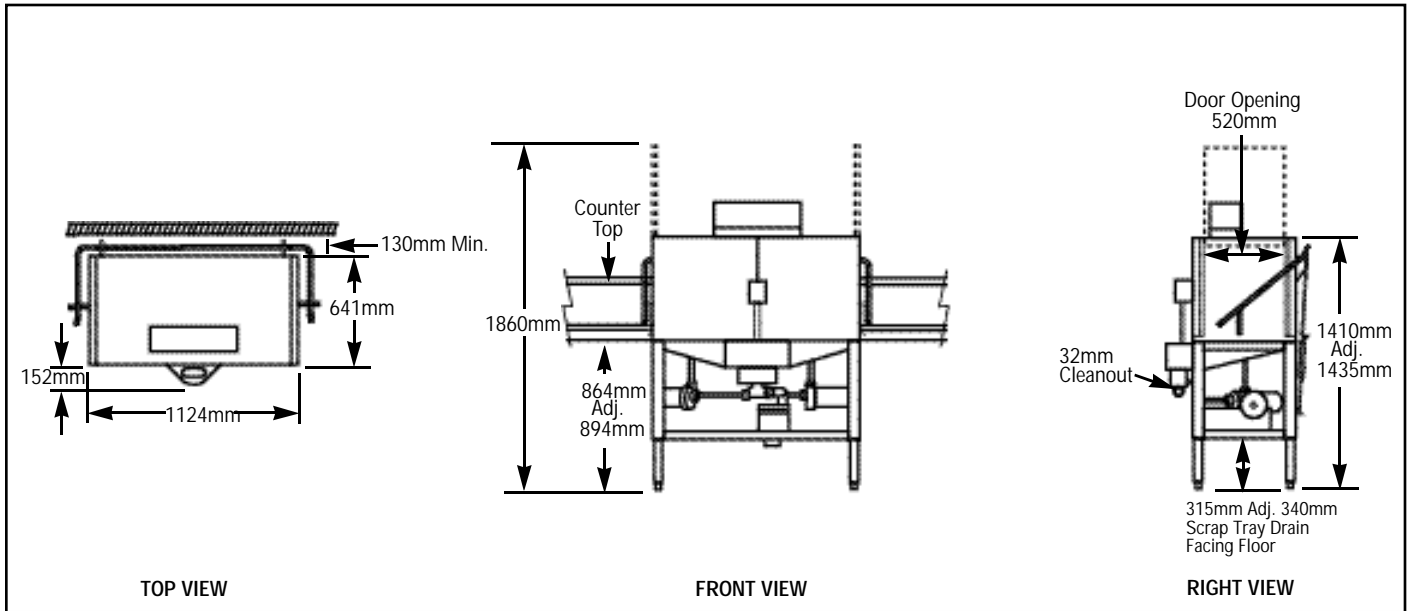

Spec. #

Specifications:

MODEL B	USA	METRIC	USA	METRIC
OPERATING CAPACITY				
RACKS PER HOUR (NSF RATED)	74	56/74		
OPERATING CYCLE				
WASH TIME-SEC	45	45		
RINSE TIME-SEC	30	30		
DWELL TIME-SEC	15	15		
TOTAL CYCLE TIME	90	90		
WASH TANK CAPACITY	3.0 GAL.	(11.4 L)		
PUMP CAPACITY	104 GPM	(394 LPM)		
OPERATING TEMPERATURE				
REQUIRED	120°F	(49°C)		
RECOMMENDED	140°F	(60°C)		
WATER CONSUMPTION				
PER CYCLE	3.0 GAL.	(11.3 L)		
PER HOUR	118.4 GPH	(448 LPH)		
WATER REQUIREMENTS				
WATER INLET	3/4"	-		
DRAIN-I.P.S.	2"	-		
WASH PUMP MOTORS HP	1	1		
DIMENSIONS				
DEPTH	25-1/4"	(64cm)		
WIDTH	44-1/4"	(112cm)		
HEIGHT	55-1/2"-56-1/2"	(141cm-143.5cm)		
STANDARD TABLE HEIGHT	34"	(86cm)		
MAXIMUM CLEARANCE FOR DISHES	17"	(43cm)		
STANDARD DISHRACK DIMENSIONS	2	2	19-3/4"X19-3/4"	(50X50cm)
ELECTRICAL RATING	VOLTS	AMPS		
	240	13		
SHIPPING WEIGHT APPROXIMATE	352#	(160kg)		

Summary Specifications: Model B

CMA Energy Mizer model B low temperature, chemical sanitizing commercial dishwasher meets NSF, UL and CSA sanitation and construction standards WITHOUT the use of BOOSTER or TANK HEATERS. The model B is constructed entirely of 304 stainless steel. Each unit automatically washes, rinses and sanitizes food service utensils in standard 20" x 20" racks. Unit comes standard with upper and lower stainless steel wash arms. The model B incorporates a pump purging system that improves results by eliminating soil and chemical carryover during rinse cycle.

Available Options

- CMA Temp-Sure™ (Self contained 12kW heater) to boost incoming water supply from 40 to 60 Centigrade
- Sanitizer Alarm
- Stainless Steel Dishtables
- Alternative cycle times
- Alternative electrical available for export

AIA #